

CUST:- M/s.

750 ML. SOHO

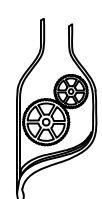
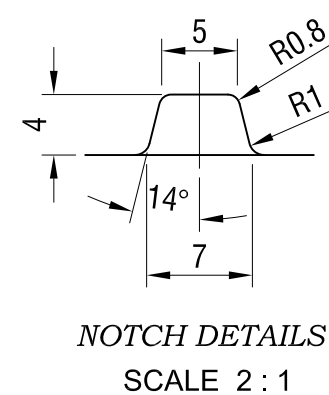
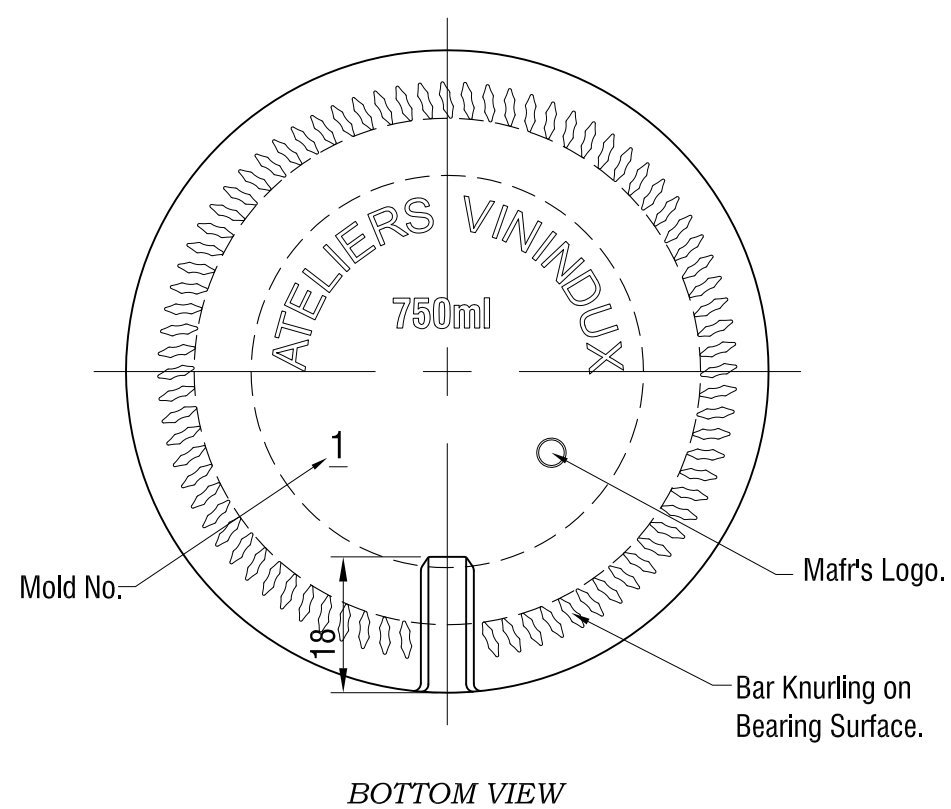
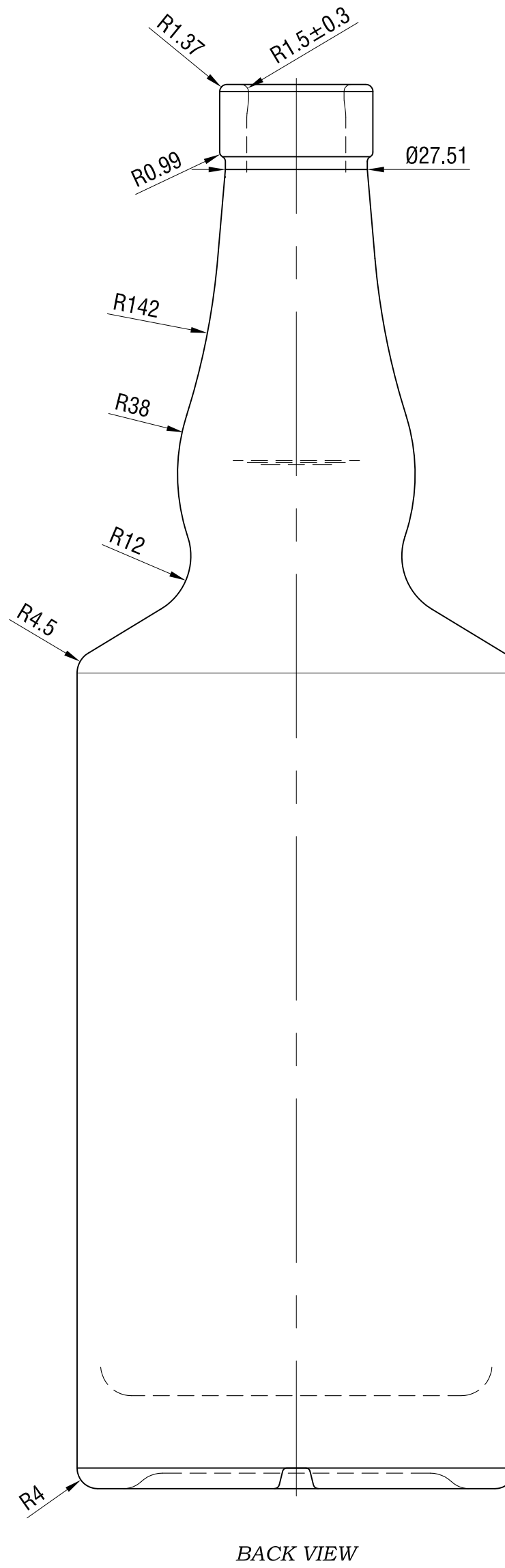
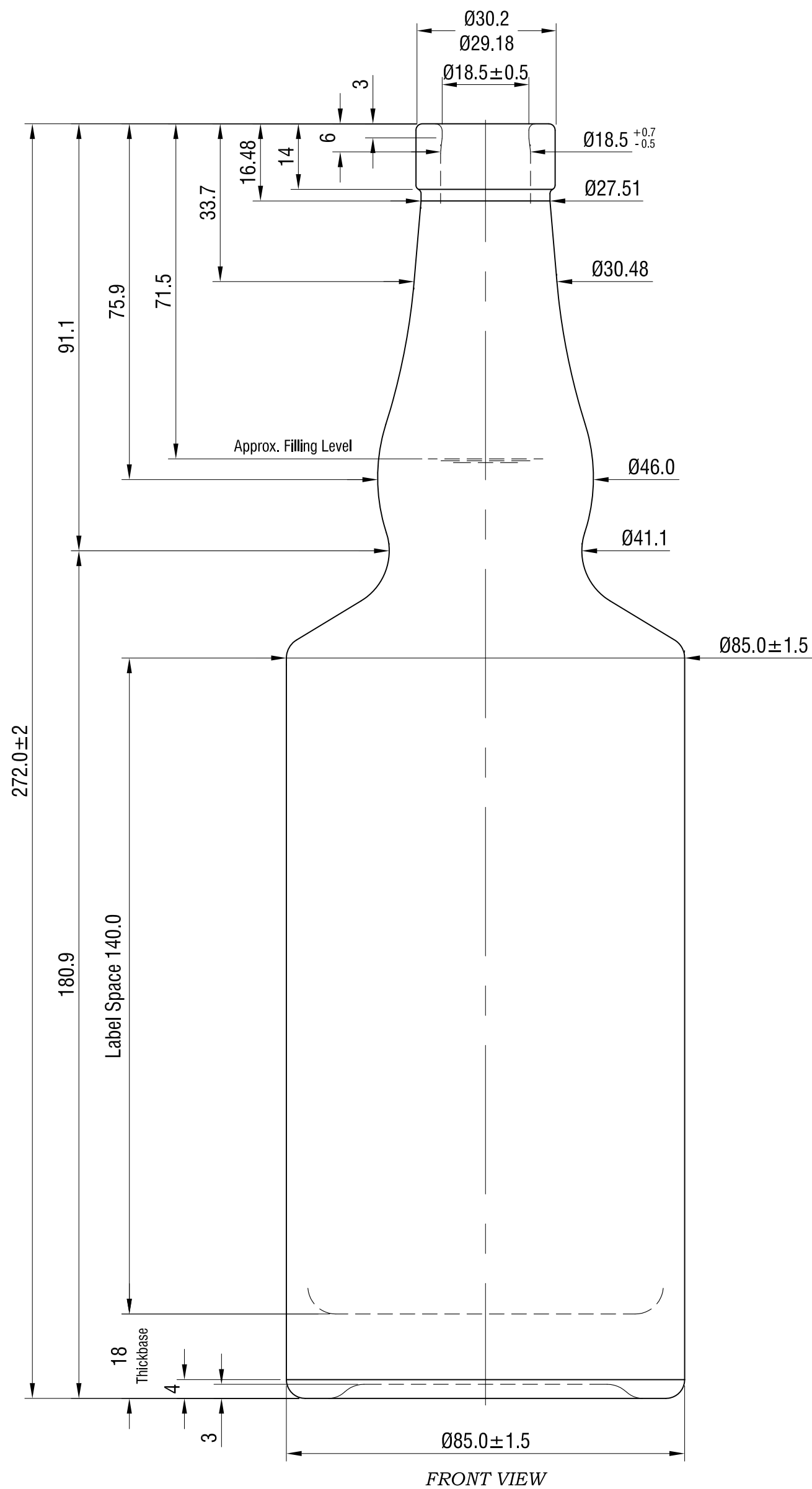

ATELIERS GLASSEX PRIVATE LIMITED
 103-105,107, Gokul Arcade 'B', Subhash Road,Vile Parle (East),
 Opp. Garaware Polyester, Mumbai-400 057 [India]
 Tel :- 91-22-61240000 Fax :- 28250166
 www.ateliersbottledesign.com

ALL DIMENSIONS ARE IN MM.& TENTATIVE UNTIL FINAL SAMPLE BOTTLE IS APPROVED.DO NOT SCALE DRAWING
 COPYRIGHTS RESERVED.NOT TO BE COPIED IN WHOLE OR PART WITHOUT WRITTEN PERMISSION FROM ATELIERS GLASSEX PVT.LTD.
 REFERENCE :- DEVP. PROCESS :- BB TILT ANGLE:-
 DRG.NO.:- GIPL-B-2494_A2

FILLING	750 ± 7 ml.	DATE	26.05.2022
BRIMFUL	788 ± 7 ml.	DRAWN	DEEPAK NF.
WEIGHT	625 ± 18 Gms.	SCALE	1 : 1 (A2)
NECK FINISH	18.5 mm TPV BAR TOP	VACUITY	71.5 mm Approx.
MIN.THR.BORE	Ø 18.0 mm.	COLOUR	FLINT