

# FULTON

750ML

## COLOUR:

● extra flint

Art.Nr:

-

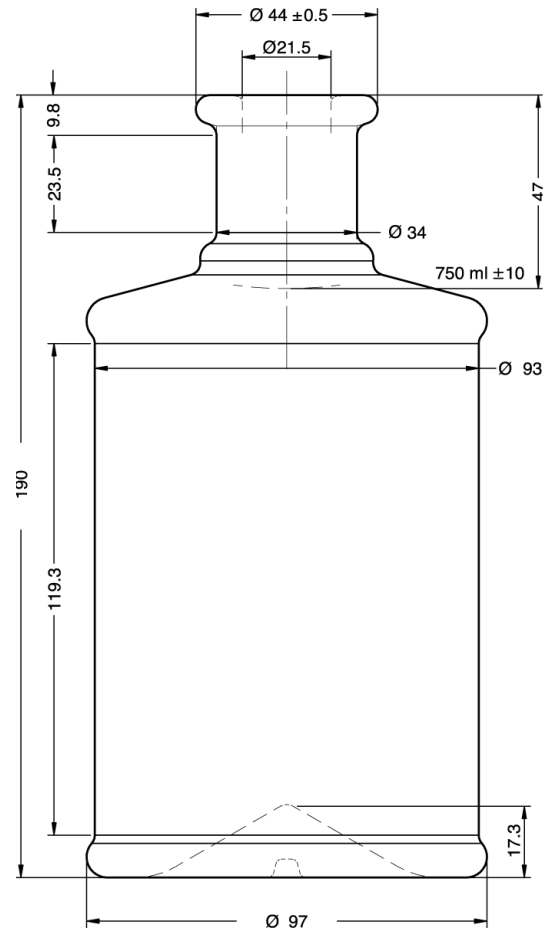

PATENTED MODEL

FIT FOR



## TECHNICAL DATA

TECHNISCHE DATEN

<b>Total Height</b> / Gesamt Höhe	190.0 mm
<b>Body Diameter</b> / Durchmesser	97/93 mm
<b>Weight</b> / Gewicht	600 gr
<b>Finish</b> / Mündung	RING 21.5/44 mm
<b>Brimful</b> / Randvoll	770 ml

The elements detailed in this document are not contractual. They are only indicative.

**REIS**  
PACKAGING EUROPE

[www.reispackaging.com](http://www.reispackaging.com)