

FULTON

100ML

COLOUR:



flint

Art.Nr:

-

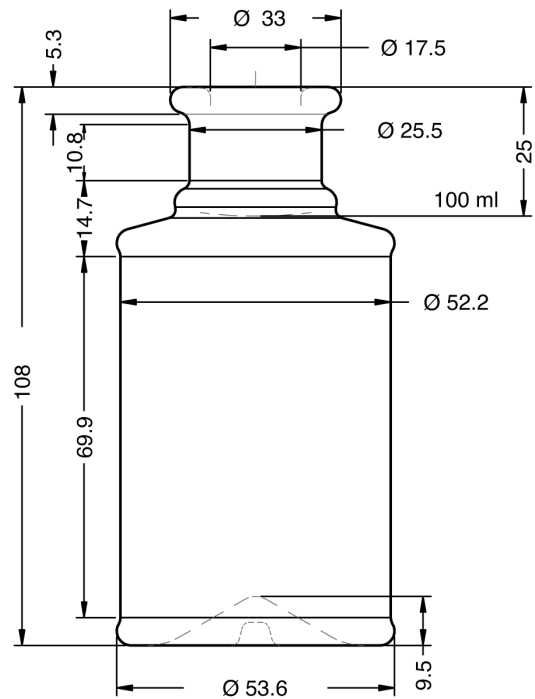

PATENTED MODEL

TECHNICAL DATA

TECHNISCHE DATEN

Total Height / Gesamt Höhe	108.0 mm
Body Diameter / Durchmesser	53.6/52.2 mm
Weight / Gewicht	200 gr
Finish / Mündung	Ring 15.5/336 mm
Brimful / Randvoll	105 ml

The elements detailed in this document are not contractual. They are only indicative.

REIS
PACKAGING EUROPE

www.reispackaging.com