

FULTON

200ML

COLOUR:

 extra flint

Art.Nr:

70121

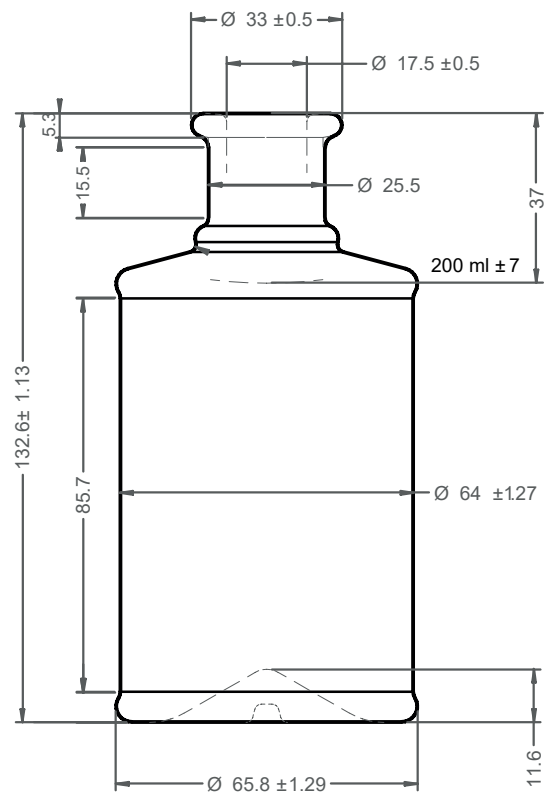

PATENTED MODEL

FIT FOR



TECHNICAL DATA

TECHNISCHE DATEN

Total Height / Gesamt Höhe	132.6 mm
Body Diameter / Durchmesser	65.6/63.8 mm mm
Weight / Gewicht	300 gr
Finish / Mündung	RING 17.5/33 mm
Brimful / Randvoll	215 ml

The elements detailed in this document are not contractual. They are only indicative.

REIS
PACKAGING EUROPE

www.reispackaging.com