

# FULTON

## 500ML

### COLOUR:

 extra flint

### Art.Nr:

70123

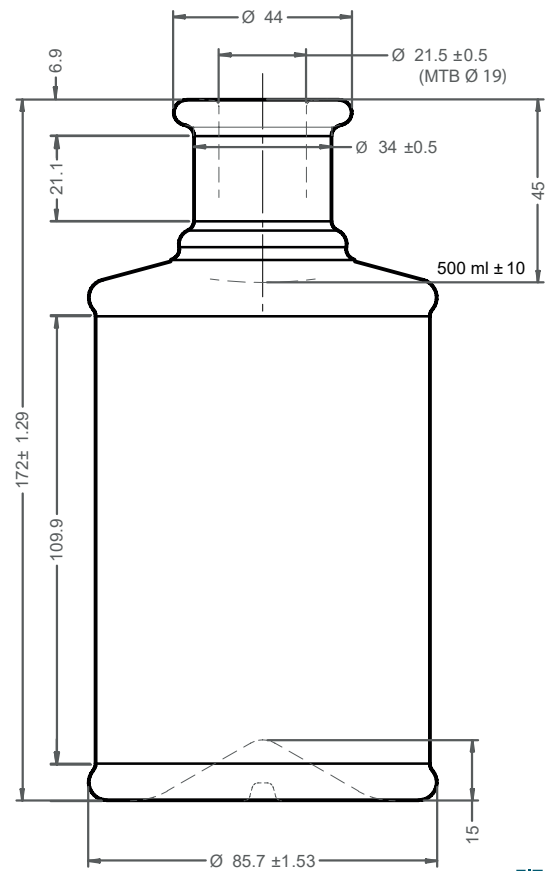

PATENTED MODEL

FIT FOR



### TECHNICAL DATA

TECHNISCHE DATEN

<b>Total Height</b> / Gesamt Höhe	172.0 mm
<b>Body Diameter</b> / Durchmesser	85.7/82.3 mm mm
<b>Weight</b> / Gewicht	500 gr
<b>Finish</b> / Mündung	RING 21.5/44 mm
<b>Brimful</b> / Randvoll	525 ml

The elements detailed in this document are not contractual. They are only indicative.

**REIS**  
PACKAGING EUROPE

www.reispackaging.com