

FULTON

1000ML

COLOUR:

 extra flint

Art.Nr:

70125

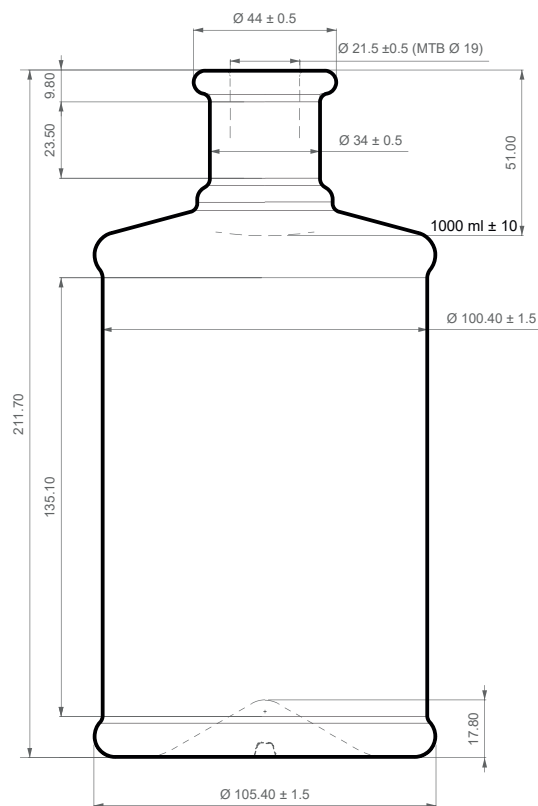

PATENTED MODEL

FIT FOR



TECHNICAL DATA

TECHNISCHE DATEN

Total Height / Gesamt Höhe	211.7 mm
Body Diameter / Durchmesser	105.2/100.4 mm mm
Weight / Gewicht	750 gr
Finish / Mündung	RING 21.5/44 mm
Brimful / Randvoll	1030 ml

The elements detailed in this document are not contractual. They are only indicative.

REIS
PACKAGING EUROPE

www.reispackaging.com