

# FULTON

## 1500ML

### COLOUR:

 extra flint

### Art.Nr:

70126

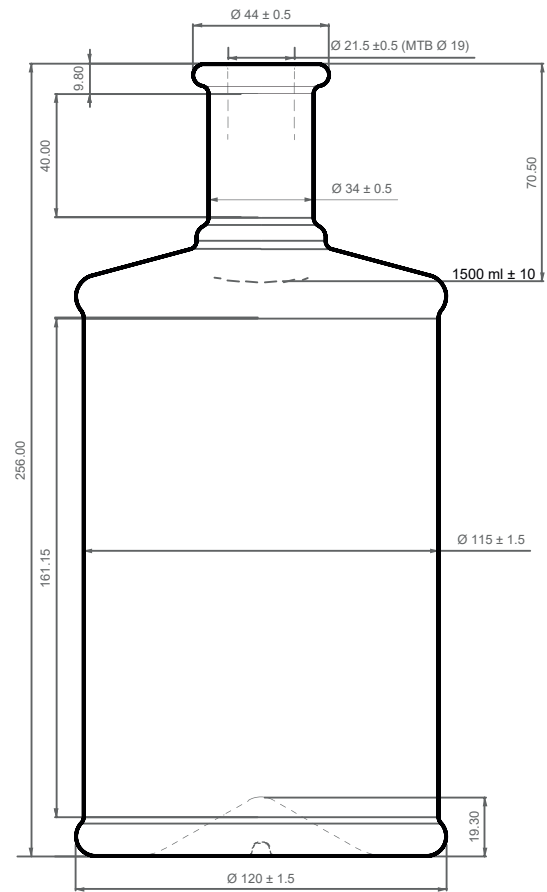

PATENTED MODEL

FIT FOR



### TECHNICAL DATA

TECHNISCHE DATEN

<b>Total Height</b> / Gesamt Höhe	256.0 mm
<b>Body Diameter</b> / Durchmesser	120.0/115.0 mm
<b>Weight</b> / Gewicht	1200 gr
<b>Finish</b> / Mündung	RING 21.5/44 mm
<b>Brimful</b> / Randvoll	1550 ml

The elements detailed in this document are not contractual. They are only indicative.

**REIS**  
PACKAGING EUROPE

www.reispackaging.com